

Almost All Digital Electronics

L/C Meter IIB

Neil Heckt

• Specifications

Range

- .001 μ Hy (1 nHy) to 100 mHy (most units measure to 150 mHy)
- .010 pF to 1 μ Fd (most units measure to 1.5 μ Fd)
- **(Capacitors must be non-polarized)**
- AUTOMATIC RANGING

Accuracy 1% of reading Typical

- Typical means the average error for 60 inductance calibration standards:
 - 20 HP 16470A standard calibration inductors
 - 16 Booton type 103A standard calibration inductors
 - 6 Booton type 62-2A standard calibration inductors
 - 18 Marconi type TM 4520 standard calibration inductors
- and 83 capacitance calibration standard
 - 7 Heathkit 0.25% capacitance calibration standards
 - 37 Vero 0.1% capacitance calibration standards
 - 39 0.5% decade capacitance calibration standard
 - 10 2% high value capacitance calibration standards
- See <http://www.aade.com/lcm2binst/HP.html> for detailed results.
- SELF-CALIBRATING

Display

16 Char intelligent LCD

Four Digit Resolution

Direct display in engineering units, ie: $L_x = 1.234 \mu\text{Hy} / C_x = 123.4 \text{ pF}$

Sampling Rate:

Approximately 5 samples / second. (will track while adjusting adjustable components)

The unit displays values in one of two modes which can be changed during operation. The “micro mode” displays values in uHy, mHy, pF, and uF when applicable. In this mode, for example, 10.00 nano-Farads displays as .01000 micro-Farads and 1 nano-Henry displays as .001 micro-Hy. It is for old timers like me and is the way many parts are marked. The “nano mode” is for those more metrically inclined. Table 1 shows how each range is displayed in each mode.

INDUCTANCE nano mode	INDUCTANCE micro mode	CAPACITANCE nano mode	CAPACITANCE micro mode
000-999 nHy	0.000 - 0.999 μ Hy	0.00 - 0.99 pF	0.00 - 0.99 pF
1.000 - 9.999 μ Hy	1.000 - 9.999 μ Hy	1.00 - 9.99 pF	1.00 - 9.99 pF
10.00 - 99.99 μ Hy	10.00 - 99.99 μ Hy	10.00 - 99.99 pF	10.00 - 99.99 pF
100.0 - 999.9 μ Hy	100.0 - 999.9 μ Hy	100.0 - 999.9 pF	100.0 - 999.9 pF
1.000 - 1.999 mHy	1.000 - 1.999 mHy	1.000 - 9.999 nF	1000 - 9999 pF
10.00 - 99.99 mHy	10.00 - 99.99 mHy	10.00 - 99.99 nF	.01000 - .09999 μ F
100.0 - 150.0 mHy *	100.0 - 150.0 mHy *	100.0 - 999.9 nF	.1000 - .9999 μ Fd
		1.000 - 1.500 μ Fd *	1.000 - 1.500 μ Fd *

TABLE 1. Display Options (* Some values may be out of range).

Operating Modes

When the Lx and Cx switches are off pressing the ZERO button sequences L/C Meter IIB through five different operating modes.

READY MEASURE n measures Lx or Cx and displays the result in "nano mode"

ie: Lx = 99 nHy, Cx = 12.34 nF

READY MEASURE u measures Lx or Cx and displays the result in "micro mode"

id: Lx = .099 uHy, Cx = .01234 uF

READY MATCHnMODE first measures a reference component Lz or Cz and displays the value in "nano mode". When the ZERO button is pressed this value is stored in RAM and the difference between it and subsequent components is displayed in "nano mode"

ie: Lx - Lz = 99 nHy, Cx - Cz = 12.34 nF

READY MATCHuMODE first measures a reference component Lz or Cz and displays the value in "micro mode". When the ZERO button is pressed this value is stored in RAM and the difference between it and subsequent components is displayed in "micro mode"

ie: Lx - Lz = .099 uHy, Cx - Cz = .01234 uF

READY MATCH%MODE first measures a reference component Lz or Cz and displays the value in "nano mode". When the ZERO button is pressed this value is stored in RAM and the ratio of the difference between it and subsequent components is displayed in percent.

ie: (Lx - Lz)/Lz*100 = 12.34%, (Cx - Cz)/Cz*100 = 12.34%

Note that a positive reading in the matching modes means Lx is greater than Lz or Cx is greater than Cz and visa versa.

L/C Meter II is intended to measure inductors and capacitors "out of the circuit". Inductors must have a reasonable Q for their value and negligible distributed capacitance for their value. I have tested it using commercially available RF chokes ranging from 0.1 micro-Henry to 1000 micro-Henry, Hash chokes up to 100 micro-Henry wound on ferrite rods, on Pi-wound RF chokes up to 7.5 milli-Henry, on toroid wound inductors up to 150 milli-Henry (such as the HI-Q series obtainable from Mouser Electronics), and on several slug tuned inductors from a Coilcraft Slot-10 designers kit (similar to the TOKO line of tunable inductors).

Stray Inductance and Capacitance

The circuit traces on the PCB, the switches, and the test leads all contribute a small amount of "Stray" inductance (Ls) and capacitance (Cs). These stray values add to the values of Lx or Cx. The unit is zeroed by pressing the ZERO switch which causes the unit to store the values of stray inductance or capacitance and subtracts them from the measured values.

To zero Ls the operator must short circuit the test leads, press Lx and then press the ZERO button. Similarly, for capacitors, the operator open circuits the test leads, presses Cx and then presses ZERO.

The stored values of Ls and Cs are saved until the operating mode is changed. When measuring components, it is not necessary to re-ZERO between components. When the operating mode is changed from MEASURE to MATCH these values are reset to zero.

If an inductor is inserted when the Cx switch is depressed it will display "NOT A CAPACITOR". This does not work for very large values of Lx and the unit may display an erroneous reading.

Putting a capacitor in when the Lx switch is pressed displays "NOT AN INDUCTOR". This is not true for very large values of Cx in which case the unit may display an erroneous reading.

L/C Meter IIB can zero out ANY value in it's range. If a value is inserted and ZERO'd the unit will display the difference between it and subsequent components similar to the MATCHnMODE and MATCHuMODEs. The difference in the MATCHxMODEs is that the range is frozen to the resolution of the initial component. This limits the minimum difference in values to be 1 part in 10,000 or .01%. The reason for this may not be obvious. The maximum resolution of the unit is four digits **at the value of the components being measured**. Consider two components, one with an exact value of 5000 pF and the other with an exact value of 5010.25 pF. The difference would be 10.25 pF, however the unit cannot resolve less than 1 pF at this range and it would be misleading to display the fractional portion of the difference.

Construction (There is a layout drawing on last page in case you cannot read the pictures)

NOTE: there is only 3/8 inch space under the display, leave enough lead length to tip regulator and two electrolytics at an angle so that the vertical dimension does not exceed 3/8 inch.

CLICK ON ANY IMAGE TO ENLARGE

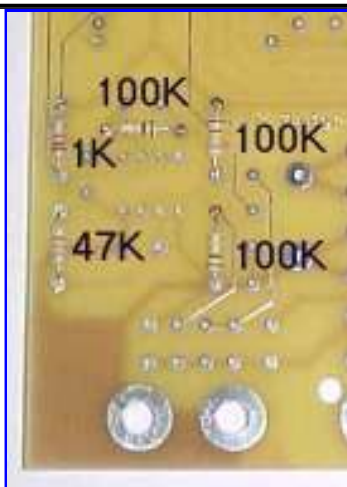

Begin by installing the resistors.

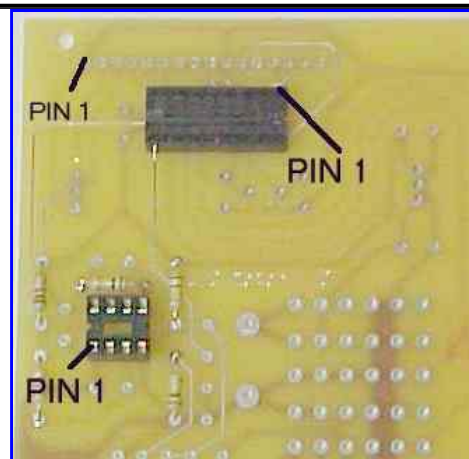

Then the IC sockets

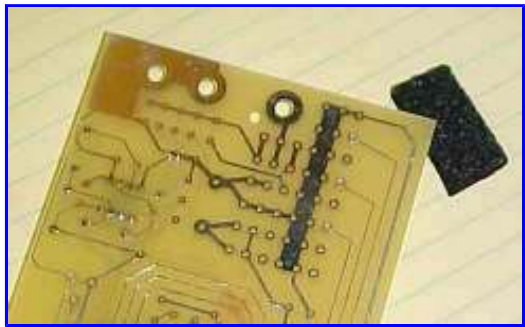

When soldering the sockets, support the corner
Using the black foam the ICs are shipped on.



If you received a 14 pin connector install it in pins 1-14
of the PCB. The 16 pin shown is the current production.

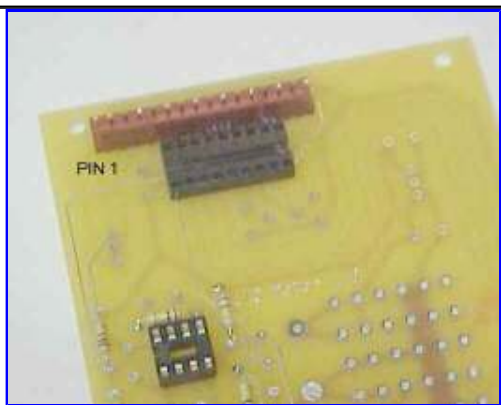

Install the connector with the guard toward the bottom of the PCB

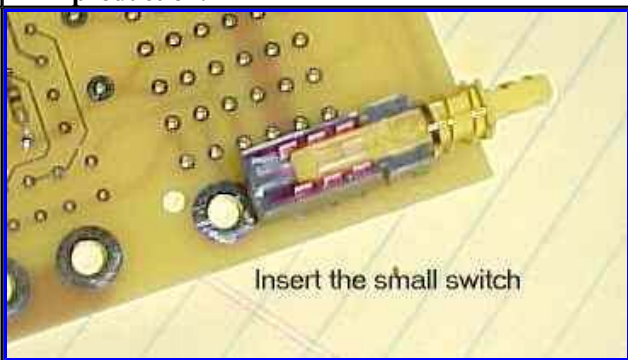

Install the small switch.

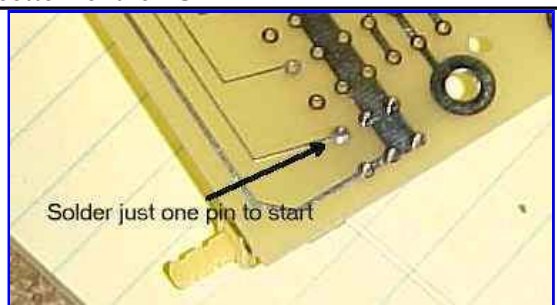

Solder just one pin

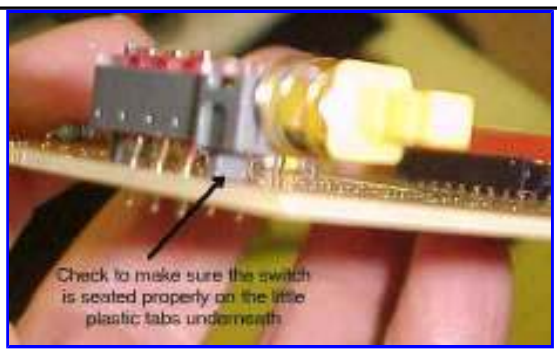

Check to make sure the switch is seated squarely on the plastic tabs then solder remaining pins.



Install the remaining three switches.

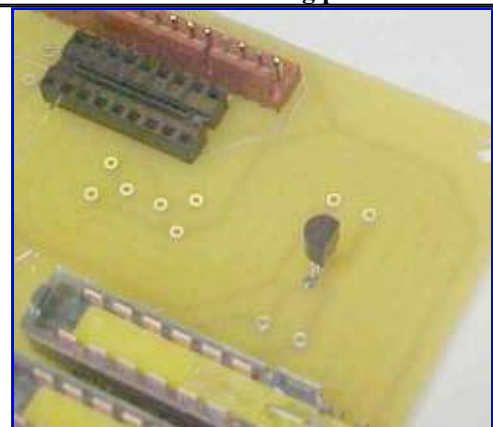

Install the voltage regulator flat side toward right

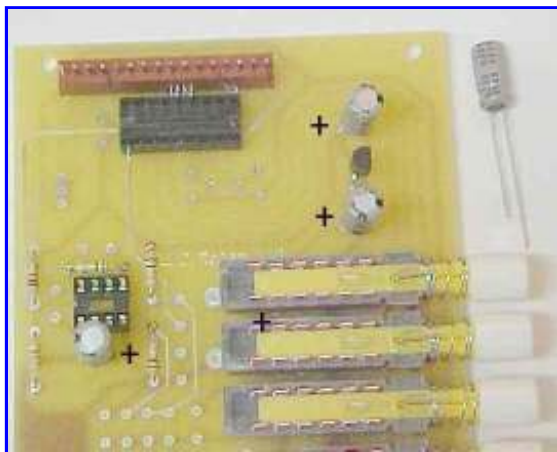

Install the three 10uF electrolytics with polarity as shown above. Do not try to mount flush to PCB. Incorrect pad spacing is intentional so they can be tipped under display module. Note the long lead on these parts is the positive lead. Install the switch knobs by pushing them onto the square switch ends.

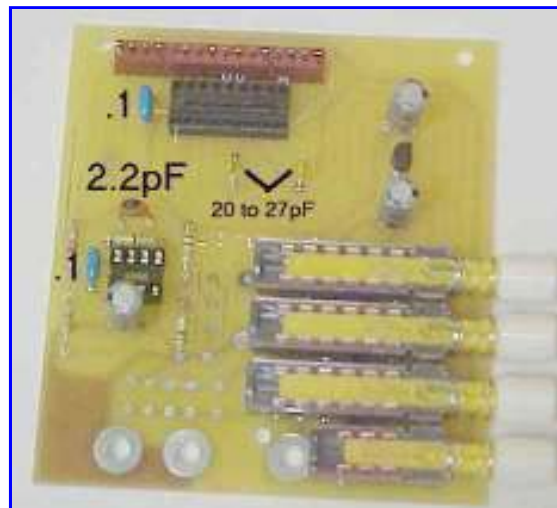

Install the two 0.1uF ceramics, the 2.2pF ceramic and the two 20 to 27pF (value not critical) ceramics

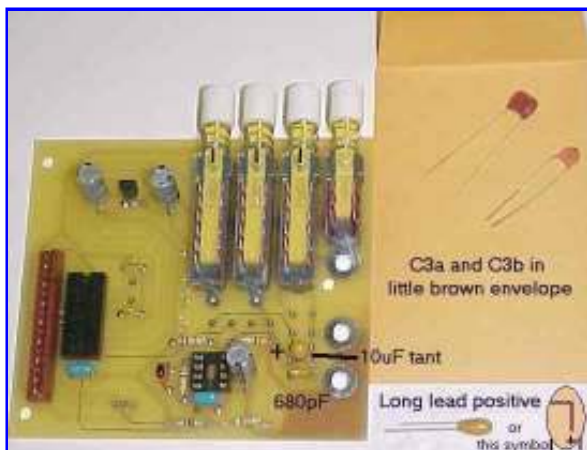

Install the 680pF ceramic, 10uF tantalum (long lead positive). C2a and b are in a little brown envelope.

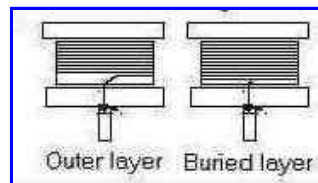

L1 installation.

I don't know why but best results are obtained if the terminal connected to the outer layer is toward the bottom of the pcb. careful inspection will reveal that the other lead clearly goes to a buried layer.

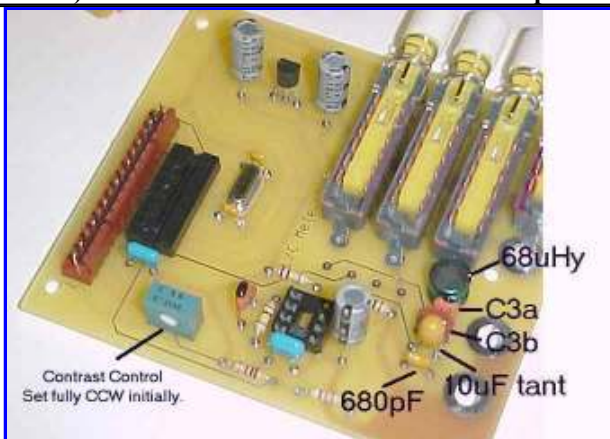

Install C2a and C2b and L1 (68uHy)
Install contrast control and initially set fully CCW.
Install the crystal between the two 22pf caps.

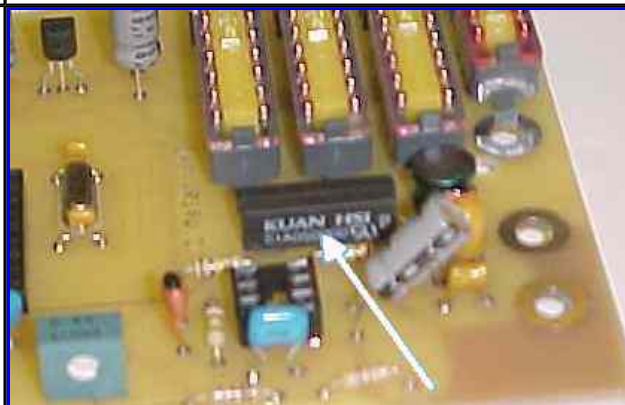

Install the relay with printing toward the LM311 socket as shown. The relay has an internal diode so it has a polarity.



Install the two spacers using #8 washer and screw from the bottom of the pcb



Install the female header connector on the display module.
If you received a 14 pin connector, use pins 1-14.



For 16 pin connector use all pads.
For 14 pin connector use pads 1-14.

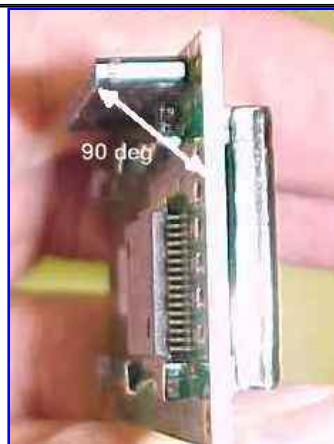

Solder only one pin, check to make sure connector is at right angle then solder remaining pins.

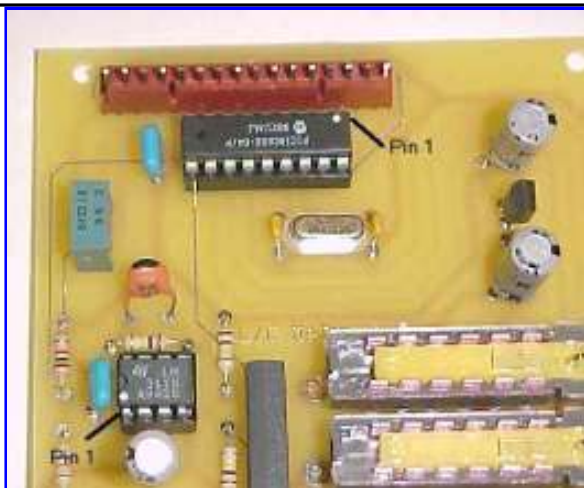

Install the PIC16C622 and LM311 as shown above with white dot indicating pin 1



Take the cover off the enclosure battery box and thread the battery wires through the cutout as shown above

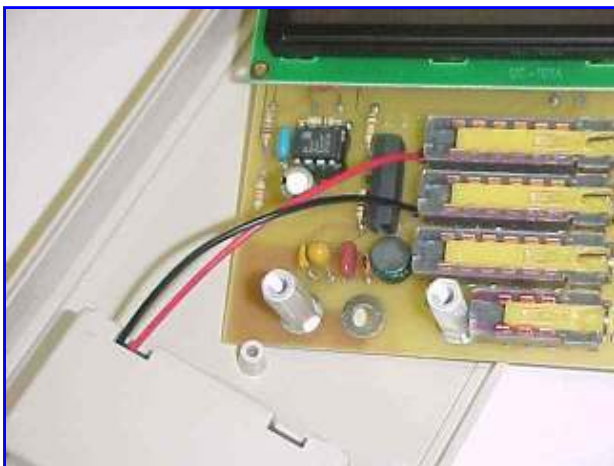

Insert those wires into the PCB as shown above and solder on the back side. At this point you can test the unit by attaching a 9 volt battery and tuning the unit on. You should see the power up sequence described in the text above.



Install the unit in the enclosure using the three #4 sheet metal screws.



Put the front cover on the enclosure. Disassemble the test jacks as shown above and discard the parts circled.



Reassemble the remaining parts and hand screw them into the threaded spacers visible through the holes in the enclosure. **Then put on the knurled parts but do not over tighten.**



Assembling the **optional** SMD probe is a bit of a no brainer. Just remember to clip the plastic part at the tips even with the metal part using a finger nail clipper as shown above in upper right.

The kit of parts is shown on the top and the finished product and how to use it on the bottom.



Put the four #2 sheet metal screws into the back to secure the enclosure.
Turn the unit on and enjoy the fruits of your labor.

The unit will display "L/C Meter IIB" for 10 seconds followed by "CALIBRATING" for two seconds followed by "READY MEASURE x". If so, your up and running. Adjust the contrast control so the background is just barely visible. Test leads should not exceed 4 inches in length with a banana plug at one end and alligator clip at the other.

Troubleshooting

It is very unlikely you will have any problems, however, if you just can't seem to get it to work I will try to fix it free except for a \$4.00 return postage and handling fee.

If it did not work, remove the PCB and carefully inspect to see you have soldered everything that should be soldered and have not soldered anything that should not be (look for solder bridges). Bad soldering accounts for 99% of units that fail to work immediately. Here are some hints on where to look.

- 1) **Blank display**, contrast control not adjusted correctly. Start with it fully counter clockwise. **This is the number one problem I get calls on.**
- 2) **On rare occasions a through-hole plating may not have gone through from the bottom to the top of the PCB.** Check those few pads on the top side that have circuit traces and solder the component lead on the top side of the PCB as well as the bottom.
- 3) **Blank display**, check 5V power to CPU and display. If you ever applied reverse voltage, even for a moment, or if you installed the PIC16C622 in backwards you have blown the 78L05 voltage regulator. Surprisingly, the PIC usually survives.
- 4) **Displays 8 black squares**, CPU not communicating with display. Check solder around CPU and display. CPU crystal not oscillating. Check with oscilloscope if possible.
- 5) **Displays WAIT, then CALIBRATING and sticks in CALIBRATING.** Oscillator (LM311) is not oscillating. Check soldering around LM311, LM311 properly installed, parts properly installed. C3 in backwards? (see note 6). Also the ZERO button may be stuck in or not soldered. Check continuity to ground from pin 13 of the CPU.
- 6) **Seems to work but readings appear way off from components marked value.** Calibration capacitors not correctly installed (you put some other part where they are supposed to go), C3 installed backward (+ terminal toward top, display end of the PCB), or relay in backwards (relay should be installed with it's part number opposite the switches and towards the LM311).

Operation

The typical stray inductance is .04 to .06 μH 's and the typical stray capacitance is 5 to 7 pF's. When measuring inductors less than 5 μH 's or capacitance's less than 50 pF's it is advisable to ZERO the unit first. For larger values the strays are insignificant to the result. It is difficult to retain a reading of 0.000 pF's because of the extreme sensitivity of the unit. Your body capacitance influences the reading. Try ZEROing the capacitance and then move your hands around the test leads without touching them. You will find you can adjust the reading a few hundredths of a pF.

To measure inductance place the unknown across the test leads and depress Lx. To measure capacitance place the unknown across the test leads and press Cx.

The oscillator tends to drift a few Hertz during the first few minutes of operation. When measuring very small values the unit should be allowed to warm up for about five minutes. With a resolution of 5 Hz, thermal drift will always occur as evidenced by a slowly drifting reading. The first readings after pressing Lx or Cx are the most accurate.

Accuracy and Resolution

L/C Meter IIB has four digit resolution which for small values of L and C are 1 nHy and .01 pF. You cannot accurately measure values this small. The resolution greatly exceeds the accuracy. You can measure values as small as .01 μ Hy and .1 pF with about 15% accuracy. You generally won't find components this small. For example a piece of wire less than one inch long is .01 μ Hy. The resolution is, however, relative and can be used for sorting a batch of similar components as it truly does indicate which are slightly larger or smaller than others. Also, for small values of inductance, the leads will contribute quite a bit to the value. Measuring from the ends of the leads instead of next to the body of the component can add up to .025 μ Hy.

For small values the frequency of operation (test frequency) is about 750 KHz decreasing to about 60 KHz at .1 μ Fd's or 10 mHy's and about 20 KHz at 1 μ Fd or 100 mHy's.

Parts List

R1, R2, R3	100K ohm 1/4 watt
R4	47K ohm 1/4 watt
R5	1000 ohm 1/4 watt
R6	10K ohm potentiometer
C1	680pF (disc ceramic marked 681)
C2a	1000pf 2% (C2a and b are packed in a little brown envelope)
C2b	5, 10, 15, 20, 24, 27, 33, or 39pf NPO as required to make exact total.
C5,C6	0.1 μ fd ceramic (blue marked 104)
C3	10 μ fd /10v Tantalum (tan tear drop shaped, observe polarity)
C4,C9,C10	10 μ fd /10v electrolytic (gray radial, observe polarity)
C7,C8	22 pf ceramic (brown monolythic marked 22J) (value may vary from 20 to 27pF)
C11	2.2pF (Brown disc with black top labeled 2.2C)
X1	8.0 MHz crystal
L1	68 μ Hy
U1	LM311N voltage comparitor
U2	PIC16C622 microcomputer
U3	LT1121CZ-5 low drop-out voltage regulator
RLY1	SPST N.O. reed relay (has diode, observe install orientation)
DISP	LM-16151 or equiv'
J1	14 or 16 pin female square post socket (install on display)
P1	14 or 16 pin male square post plug (install on PCB)
Lx, Cx, PWR	DPDT alternate action SW
ZERO	DPDT momentary SW
Test Jacks	5 way binding posts

Almost All Digital Electronics www.aade.com

1412 Elm St. S.E.

Auburn, WA 98092

TECHNICAL SUPPORT

Voice 253-351-9316 9AM-9PM (usually available on weekends)

FAX 253-931-1940

e-mail neil@aade.com